



PRECISION AC/DC SHUNTS

THE BEST IN AC SHUNT PERFORMANCE WITH OUR 7350 POWER BASED AND 7340 VOLTAGE BASED SHUNTS

High Stability, Precision Power or Voltage Rated AC/DC Current Calibration Standards

GUILDLINE INSTRUMENTS provides two series of the best performing, most compact, wide-band AC current shunts that are commercially available from any manufacturer today!

Each AC Shunt Series provides unique design features that allow customers to select the AC Shunt most appropriate for their measurement application.



PROVIDING TWO SERIES FOR AC CURRENT SHUNTS, THE 7350 POWER BASED SERIES AND THE 7340 VOLTAGE BASED SERIES. BOTH SERIES PROVIDE FOR PRECISION AC CURRENT MEASUREMENTS TO 100 A AND A WIDE 100 KHZ FREQUENCY BANDWIDTH!

FEATURES

- High Current Values to 100 Amps
- Accuracy to ± 100 ppm
- AC/DC Difference Essentially Zero at Power Frequencies, and < 10 ppm up to 10 kHz
- Phase Displacement typically 5 to 10X Better than nearest competitor from 10kHz to 100 kHz
- Widest Available Bandwidth DC to 100 kHz
- Excellent 1-Year Stabilities
- Low Temperature Coefficients 2.5 ppm/ $^{\circ}$ C
- Both Series Provide a 4-Wire, True Non-Inductive Patented Design
- 7340 Series Provides 10 Current Values from 10 mA to 100 A with Output Voltages from 0.2 to 1.0 V
- 7350 Series Provides 6 Ohmic Values with Currents from 0.1 A to 25 A with Power up to 10 Watts
- Ruggedized EMI Shielded Enclosure
- Designed for Ease of Use and Complete Operational Safety

Guildline Instruments provides the best performing, most compact, high frequency AC/DC current shunts that are commercially available. The 7340 Series provides a range of output voltages designed for use with thermal converters, while the 7350 Series is designed to be used across a much wider operation range based on output power (watts). Both Series are unique with respect to engineering and design, compact size and EMI shielding.

The 7340 and 7350 Series of four-terminal AC Current Shunts feature low uncertainty (high accuracy), low temperature coefficients and excellent stability. These new shunts are designed to be purely resistive with extremely small values of reactance. These shunts may be used over a wide frequency range from DC to 100 kHz.

The 7340 Series, with 10 available Current models, is designed to provide an output voltage in the range of 0.2 to 1.0 Volt for specified current models from 10 mA to 100 A. For the higher current ranges above 3 A the model 73401 Forced Convection Unit is used to provide air cooling. A buffer amplifier is also provided for use with low currents.

Precision AC Shunts

Guildline's 7350 Series of Precision AC shunts have an appearance and performance similar to the 7340 Series. The 7350 Series, with 6 available Ohmic models, are designed to provide power dissipation of up to 10 Watts with current capabilities from 0.1 Ampere up to 25 A, and frequencies to 100 kHz. The 7350 Series does not require the model 73401 Forced Convection Unit for high currents.

Extremely accurate AC Current measurement can be up to 25 Amperes with the 7350 Series and up to 100 Amperes with the 7340 Series at frequencies up to 100 kHz. The lower value shunts (below 10 Ω) may also be used as burdens for current transformers, making the measurement of higher currents possible.

The shunts can also be placed in AC current circuits where the phase relationships between currents or voltages needs to be measured. At power frequencies the Phase Angle Displacement at 10 A is typically much better than 4 m° ($<70 \text{ } \mu\text{rad}$).

7340 Series (VOLTAGE BASED):

The 7340 Series offers 10 models with current measurements from 10 mA all the way to 100 Amperes. The 7340 AC Current Shunts can be used for a variety of AC/DC current measurement applications and have a nominal impedance range of 100 Ω to 0.004 Ω . The frequency bandwidth of this series is 100 kHz for all current outputs. For low currents a buffer amplifier is available.



The output (Voltage) connector on the front face of all models within both series is a BNC type for connection to the potential measuring device. UHF Type connectors are provided for currents up to 25 Amperes on the back face of the shunt and LC type connectors are provided for current ranges above 25 Amperes.

The very small phase shift of the 7340 shunts makes accurate high-frequency power measurements possible. As a result of the very small phase shift across the shunts, the output voltage of the shunts faithfully reproduces the current waveform even under badly distorted or pulsed current conditions. This makes the shunts useful when examining complex and distorted current waveforms. Like the 7340, the 7350 Series has outstanding phase displacement. From 10 kHz to 100 kHz Frequencies, both Series are typically 5 to 10x better than the nearest competitor. A table is provided with typical phase displacement in the specifications. This performance is much better than any other commercially available AC shunt.

Additionally, the shunts are effective in many other classical measurement, standards, or calibration laboratory applications. Besides precision AC Current measurements, these shunts are also an excellent choice when making AC power and energy measurements using watt-meters or watt-hour meters.



7350 Series (POWER BASED):

The 7350 Series of four-terminal AC Current Shunts are designed to be a lower uncertainty and more stable replacement of the successful Guildline 7320 series. These patented shunts also have a non-inductive design and are essentially purely resistive. With a ruggedized and shielded enclosure, the 7350 series shunts are constructed with very small values of reactance.



Like the 7340 models, the output (Voltage) connector on the front face is a BNC type connector. UHF Type connectors are provided for currents up to 25 Amperes.

The 7350 Series are ideal for use over a wide frequency range from DC to 100 kHz with low uncertainty (high accuracy), low temperature coefficients and excellent stability. To suit a wide range of customers and applications, the 7350 Series shunts provide power dissipation capability of up to 10 Watts and a maximum current capability up to 25 A. The AC Current Shunts can be used for a variety of AC/DC current measurement applications and have a nominal impedance range of 0.01 Ω to 1000 Ω .



Applications include the accurate measurement of AC current, calibration of AC shunts and clamp-on meters, calibration of current ranges of multi-function calibrators, high accuracy DVM's and transconductance amplifiers; as well as providing a traceable current signal using a traceable voltage standard from DC to 100 kHz.

Guildline AC Precision Shunts - Designed Like No Other AC Shunt Manufactured Today!

Many common AC shunts employ an Open Radial Design (i.e. Squirrel Cage). This is a National Measurement Institute (NMI) design that has been copied by many commercial manufacturers. However, it does not have a ruggedized construction, EMI shielding, and can only be used in a very tightly controlled environment by experienced personnel.

Example Open Radial Design

The Open Radial Design provides good measurements but does present challenges for commercial laboratory applications. It uses an open structure to counter heat buildup which exposes the precision resistance elements, uses long electrical paths (13 inches or more for high current models) which means a larger time constant, provides no protection against EMI, is susceptible to environmental effects including humidity or pressure, and is easily damaged. As an example, most designs if used outside of 50% humidity, must have a 20 ppm or more added to specifications. With the squirrel cage design, users must be fully aware and in control of environmental conditions, test setups and operator (equipment) safety. Metal tables or other nearby large metal objects, overhead lighting, air flow, and other environmental factors have a dramatic affect on readings. High heat transfer to connectors, due to the design, also provides issues for operators making connections.

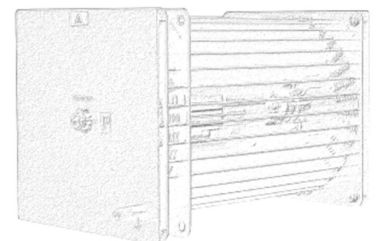

Precision AC Shunts

Physical support must be uniform across an open radial shunt so the resistance elements or electrical traces do not twist or bend – and this must be done without using metal. In addition, the large size results in a larger phase angle shift, especially at higher frequencies. Finally with exposed resistance elements, dirt, temperature or even items falling into the shunt (such as pens, etc) provide concerns for safety.

After review of the open radial design, Guildline decided to develop a new series of AC Shunts that incorporate design features to: improve performance in normal laboratory conditions, provide a more durable shunt, and to ensure safe operation for personnel. This has resulted in the patented 7340 and 7350 Series of AC Shunts. These Shunts incorporate many features that no other shunt can match. Features that allow the best in performance, operation and usage over a wide variety of conditions!

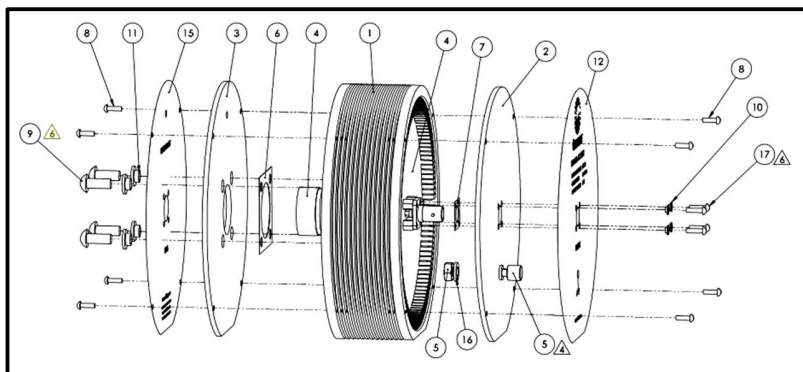

It starts with a well designed, EMI shielded, ruggedized case. You can see from the exploded diagram that the 7340/7350 case protects the resistive elements and all shunt circuitry. The shielded case also greatly reduces EMI effects. This design ensures there are no long electrical paths or traces which reduces phase shifts. All these features mean you do not have to worry about compensating for AC measurement parasites during the measurement or using special laboratory conditions.

The 7340/7350 Series design also provides many other benefits. The 100 Ampere Model runs at 1/2 the power at any current load. This means less heat to dissipate - and Guildline does provide an optional Forced Air Unit to further improve measurements at higher power levels (i.e. normally only required for power greater than 10 Watts). Each 7340 Shunt also has a wider range of operation, so the Series requires fewer shunts to maintain and calibrate. This is a significant savings when considering the cost of purchase and especially calibration.

The 7340 and 7350 Series provide an innovative and modern design for today's laboratories while providing the best in measurement performance.

AC Shunt Design and Specifications

So - how effective is the patented design? If you look at the NMI measured values for 3 of the 7340 models shown to the right, you will see the best performance in AC-DC transfers available for a commercial wideband AC Shunt. This shows that you can have the best in performance coupled with operational safety, ease of use, EMI protection and a compact ruggedized case. Note that these values and shunts were not hand selected, but actual performance with shunts that were used in a customer's laboratory for 3 years.

Shunt 7340-1A		SN:	
input current	frequency	ac-dc transfer difference in $\mu\text{A/A}$	expanded uncertainty in $\mu\text{A/A}$
1 A	100 Hz	0	4
1 A	1 kHz	0	4
1 A	10 kHz	0	4
1 A	100 kHz	+12	10
Shunt 7340-3A		SN:	
input current	frequency	ac-dc transfer difference in $\mu\text{A/A}$	expanded uncertainty in $\mu\text{A/A}$
3 A	100 Hz	0	5
3 A	1 kHz	0	5
3 A	10 kHz	-1	5
3 A	100 kHz	-32	20
Shunt 7340-10A		SN:	
input current	frequency	ac-dc transfer difference in $\mu\text{A/A}$	expanded uncertainty in $\mu\text{A/A}$
10 A	100 Hz	+1	20
10 A	1 kHz	0	20
10 A	10 kHz	-2	20
10 A	100 kHz	-65	75

Precision AC Shunts

The expanded uncertainty listed in the previous calibration certificate is the actual uncertainty of the NMI that performed the calibration on these shunts.

For high currents, below are test results from two different NMI's that calibrated two different 7340-100 Ampere Models. Note that you will see there can be a difference in NMI's expanded uncertainty and capabilities that have an impact on the AC-DC Transfer Uncertainty. That said, the results of these two 100 Ampere models show the superior performance of Guildline's 7340 AC Shunts, even at currents up to 100 Amperes with frequencies to 100 kHz.

Shunt 7340-100A			
input current	frequency	ac-dc transfer difference in $\mu\text{A/A}$	expanded uncertainty in $\mu\text{A/A}$
100 A	100 Hz	-5	40
100 A	1 kHz	0	40
100 A	10 kHz	-40	40
100 A	100 kHz	-249	160

Guildline Model 7340-100 A					
Frequency Hz	AC-DC Difference ($\mu\Omega/\Omega$)		Expanded Uncertainty ($\mu\Omega/\Omega$)		
	50 A	85 A	Frequency Hz	50 A	85 A
100	-2	-2	100	28	28
1000	-5	-5	1000	28	28
10000	-17	-17	10000	28	25
50000	-27	-23	50000	33	30
100000	-99	-91	100000	39	39

And this performance is also provided with the 7350 Series. If you examine the chart to the right, you will find NMI Results for our 7350-0.01 Ω Model which is rated up to 25 Amperes. Of interest is that this shunt was measured at up to 30 Amperes (20% over-range of the maximum recommended current). You can see that even in an over-current situation, the measurement performance is excellent.

Frequency Hz	Model 7350-0.01 AC-DC Difference ($\mu\Omega/\Omega$)			
	15A	20A	25A	30A
50	1	0	0	1
100	0	-1	-1	-2
500	0	0	0	1
1000	0	-1	0	0
10000	-1	-3	-3	-3
50000	-50	-49	-47	-48
100000	-141	-139	-139	-143

AC/DC Difference is typically < 5 ppm for ALL shunts \leq 25 A up to 10 kHz; and < 10 ppm for all shunts \geq 50A up to 1 kHz!

AC Shunt Accessories



Guildline provides a complete line of accessories for the 7340's and 7350 Series. This includes adaptors required for calibration, gender changing and different types of connections. We can provide Forced Air Cooling Units, precision cables with different connectors, and even user specified connectors (if available). Transit cases are also available to protect your investment. Contact Guildline with any question you have about accessories.



Performance Specifications – There are 2 tables (levels) of performance specifications listed for the 7340 and the 7350 Series. These absolute specifications are based on the internal calibration capabilities from Guildline and the calibration capabilities and uncertainties of a National Measurement Institute (NMI) who can provide low uncertainties for AC/DC Difference. The unique design of the AC Shunts means that for higher frequencies, and dependent on the ohmic value, the AC-DC Difference will either be capacitive or inductive producing only a positive or negative difference. The final reported result could be outside these parameters (e.g. slightly positive or slightly negative) depending on the uncertainty of laboratory performing measurement.

Precision AC Shunts

7340 SERIES (VOLTAGE BASED)		12 MONTH MAXIMUM AC-DC DIFFERENCE ¹ (in ppm @ 23°C ± 1°C <50% RH)							
		National Measurement Institute (NMI) Verification				Guildline (Factory) Verification			
Model (Nominal Current)		1 kHz	10 kHz	30 kHz ²	100 kHz ²	1 kHz	10 kHz	30 kHz ²	100 kHz ²
7340-0.01A		± 10	-0 ~ + 10	-0 ~ + 20	-0 ~ + 80	± 25	-0 ~ + 25	-0 ~ + 50	-0 ~ + 100
7340-0.03A		± 10	-0 ~ + 10	-0 ~ + 15	-0 ~ + 40	± 25	-0 ~ + 25	-0 ~ + 45	-0 ~ + 60
7340-0.1A		± 10	± 10	± 10	± 25	± 25	± 25	± 30	± 35
7340-0.3A		± 10	± 10	± 10	± 20	± 25	± 25	± 30	± 35
7340-1A		± 10	± 10	± 10	± 20	± 25	± 30	± 30	± 35
7340-3A		± 10	± 15	± 20	-50 ~ + 0	± 25	± 30	± 30	-70 ~ + 0
7340-10A		± 25	± 30	± 45	-100 ~ + 0	± 30	± 40	± 70	-140 ~ + 0
7340-25A		± 35	± 40	-60 ~ + 0	-140 ~ + 0	± 35	± 60	-80 ~ + 0	-160 ~ + 0
7340-50A		± 35	-40 ~ + 0	-60 ~ + 0	-150 ~ + 0	± 35	-80 ~ + 0	-80 ~ + 0	-180 ~ + 0
7340-100A		± 40	-60 ~ + 0	-110 ~ + 0	-250 ~ + 0	± 40	-100 ~ + 0	-140 ~ + 0	-300 ~ + 0

Above uncertainties are stated at k=2 and include both relative uncertainties and complete measurement uncertainties.

7340 SERIES (VOLTAGE BASED)			GENERAL SPECIFICATIONS (@ 23°C ± 1°C <50% RH)				
MODEL (NOMINAL CURRENT)	CURRENT RANGE ⁷	NOMINAL RESISTANCE (OHMS)	INITIAL TOLERANCE ³ (± ppm)	OUTPUT VOLTAGE RANGE (V)	DC STABILITY (± ppm)	COEFFICIENTS ⁴	
						TEMPERATURE ± ppm/°C	POWER ± ppm/WATT
7340-0.01 A	0.003 – 0.01	100	100	0.3 – 1	16	2.5	3
7340-0.03 A	0.01 – 0.033	30	100	0.3 – 1	16	3.5	3
7340-0.1 A	0.03 – 0.1	10	100	0.3 – 1	16	2.5	3
7340-0.3 A	0.1 – 0.33	3	100	0.3 – 1	16	3.5	3
7340-1 A	0.3 – 1	1	100	0.3 – 1	16	4.0	3
7340-3 A	1 – 3.3	0.3	100	0.3 – 1	16	4.0	4
7340-10 A	3 – 10	0.1	100	0.3 – 1	16	4.0	4.5
7340-25 A	10 – 25	0.03	100	0.3 – 0.75	16	4.5	5
7340-50 A	25 – 50	0.01	125	0.25 – 0.5	16	4.5	5.5
7340-100 A	50 – 100	0.004	150	0.20 – 0.4	16	4.5	6

7340 SERIES DIMENSIONS AND CONNECTORS								
7340 MODEL	Width ⁶		Diameter		Weight		Connector	
	inch	mm	inch	mm	lbs	kg	Output	Input
All Models 0.01 A to 1A	2.8	71.4	3.5	88.9	0.8	0.35	BNC	UHF
All Models 3 A to 25 A	2.8	71.4	6.63	168.4	1.8	0.82	BNC	UHF
50 A & 100 A Models	3.8	115	6.63	168.4	2.6	1.2	BNC	LC

Precision AC Shunts

7350 SERIES (POWER BASED)		12 MONTH MAXIMUM AC-DC DIFFERENCE ¹ (in ppm @ 23°C ± 1°C <50% RH)							
Model (Nominal Resistance)	National Measurement Institute (NMI) Verification				Guildline (Factory) Verification				
	1 kHz	10 kHz	30 kHz ²	100 kHz ²	1 kHz	10 kHz	30 kHz ²	100 kHz ²	
7350-0.01 Ω	± 35	-40 ~ + 0	-60 ~ + 0	-150 ~ + 0	± 50	±60	-100 ~ + 0	-250 ~ + 0	
7350-0.1 Ω	± 25	± 30	± 45	-100 ~ + 0	± 40	±50	- 60 ~ + 0	-200 ~ + 0	
7350-1 Ω	± 20	± 20	± 35	-50 ~ + 0	± 30	±40	- 50 ~ + 0	-150 ~ + 0	
7350-10 Ω	± 20	± 20	- 0 ~ + 40	- 0 ~ + 140	± 30	±40	- 0 ~ + 70	- 0 ~ + 200	
7350-100 Ω	± 40	- 0 ~ + 100	- 0 ~ + 400	- 0 ~ + 1000	± 50	- 0 ~ + 200	- 0 ~ + 600	- 0 ~ + 1600	
7350-1000 Ω	± 45	- 0 ~ + 200	- 0 ~ + 800	- 0 ~ + 4000	± 55	- 0 ~ + 500	- 0 ~ + 2000	- 0 ~ + 6000	

Above uncertainties are stated at k=2 and include both relative uncertainties and complete measurement uncertainties.

7350 SERIES (POWER BASED)			GENERAL SPECIFICATIONS (@ 23°C ± 1°C <50% RH)				
MODEL (NOMINAL RESISTANCE)	INITIAL TOLERANCE ³ ± ppm	DC STABILITY ± ppm	Maximum			COEFFICIENTS ^{4, 5}	
			VOLTAGE (V)	CURRENT (A)	POWER (W)	TEMPERATURE ± ppm/°C	POWER ± ppm/WATT
7350-0.01 Ω	150	20	0.25	25	6.3	4	4.5
7350-0.1 Ω	125	20	1	10	10	3	4
7350-1 Ω	100	20	3.2	3.2	10	2.5	3.5
7350-10 Ω	100	20	10	1	10	2	3
7350-100 Ω	100	20	32	0.32	10	2	2
7350-1000 Ω	100	20	100	0.1	10	2	2

7350 SERIES DIMENSIONS AND CONNECTORS								
Resistance Model	Width ⁶		Diameter		Weight		Connector	
	inch	mm	inch	mm	lbs	kg	Output	Input
All 7350 Series Models	2.8	71.4	6.63	168.4	1.8	0.82	BNC	UHF

Notes: All Specifications

Note 1: Calibrated in air at the minimum and maximum of the current range at 23°C ± 1°C at DC and 1kHz, 10 kHz, 30 kHz and 100 kHz frequencies. Models with currents above 3 A are calibrated with the forced convection unit model 73401. Calibration of resistance and AC-DC Difference values are referred to the unit of resistance as maintained by a National Metrology Institute and are expressed as a total uncertainty with a coverage factor of k=2. AC-DC Difference is defined as the difference between a sinusoidal alternating current required for a given output.

Note 2: The unique design of the 7340's means that for higher frequencies, and dependent on the ohmic value, the AC-DC Difference will either be capacitive or inductive producing only a positive or negative difference. The final reported result could be outside these parameters (e.g. slightly positive or slightly negative) depending on the uncertainty of the laboratory performing the measurement.

Note 3: Initial Tolerance is defined as the maximum variation of resistance mean DC values as initially adjusted at the point of sale.

Note 4: Power coefficients are specified using the 73401 Forced Convection Unit for currents above 3A for the model 7340 Series.

Note 5: No Forced Air Unit is required with the 7350 Series. Shunts may be used up to maximum wattage with no cooling required.

Note 6: Width Size is case to case and does not include terminal size.

Note 7: Current shunts may be used at current levels below the specified range but with reduced output voltages.

Precision AC Shunts

7340 AND 7350 SERIES TYPICAL PHASE DISPLACEMENT

Input Current	1 kHz	20 kHz	100 kHz
10 mA – 300 mA	< 0.001 °	< 0.004 °	< 0.025 °
300 mA to 3A	< 0.002 °	< 0.008 °	< 0.050 °
3A to 25 A	< 0.004 °	< 0.010 °	< 0.060 °
25A to 100A	< 0.008 °	< 0.040 °	< 0.150 °

ENVIRONMENTAL (APPLIES TO BOTH 7340 AND 7350 SERIES)

Operating	Temperature	Humidity	Storage	Temperature	Humidity
	18 °C to 28 °C	< 50% RH non-condensing		-20 °C to 60 °C	15% to 80% RH

Guidline Instruments provides an **industry leading two year warranty** on every 7340 and 7350 Shunt and on all associated accessories. We know that the **7340 and 7350 Shunts will work for you** out of the box and in the future... and we back it up.

ORDERING INFORMATION

7340-X (X = Model Amperage)	7340 AC/DC Voltage Based Current Shunt : Amperage models available are 10 mA, 50 mA, 100 mA, 300 mA, 1 A, 3 A, 10 A, 25 A, 50 A, 100 A
/CC	Certificate of Conformance Included
/TM	Technical Manual included
73401	Forced Air Convection Unit (Currents 10A and higher)
73502-100	100A Serial Connection Adapter
73411	Adapter LC Male to N Female
73412	Adapter LC Male to LC Male
73413	Adapter LC TO Cable
73414	LC Female to N Female
7350-X (X = Model Resistance)	7350 AC/DC Power Based Current Shunt : Resistance models available are 0.01Ω, 0.1Ω, 1.0Ω, 10Ω, 100Ω, 1000Ω
/CC	Certificate of Conformance Included
/TM	Technical Manual included
Options (Both Models)	
/NMI	National Measurement Institute Calibration
73502-30	30A and Below Serial Connection Adapter
73503	Adapter Kit
Case	Custom Transit Case
SM	Service Manual

GUILDLINE IS DISTRIBUTED BY:



www.EvoMesire.it